

## BI-CUTTER SCREENLESS GRANULATORS

### MODEL: SR1517

Patent # 6,450,427

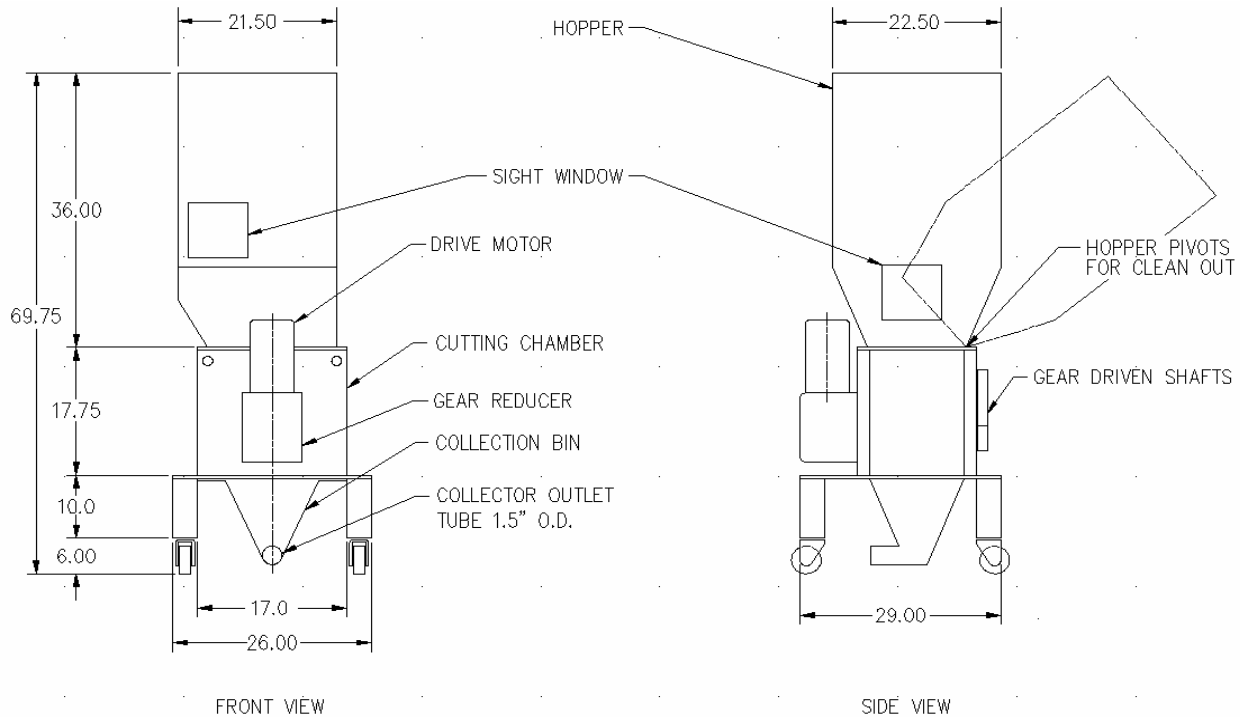

### Machine Specifications SR1517 (specifications are subject to change without notice)

Cutting Chamber W x L	15" x 17"	Shipping Weight ^	910 lb.
Motor Horsepower	2HP/1.5kw	Throughput Per Hour*^	Up to 65 lb.
Rotation Speed of S-Blade (Upper/First Stage)	18 RPM	Collector Bin Capacity*^	Up to 25 lb.
Rotation Speed of Rotary Cutter (Lower/Second Stage)	60 RPM	<b>Custom Options:</b> (including but not limited to the following)	<b>Electrical Options:</b> (including but not limited to the following:
Standard Gear Ratio	30:1	4x5mm, 5x6mm, 6x8mm, 8x10mm Cutters	Auto-Stop Reverse
Rotary Cutter and Granule Size (Lower/Second Stage)	(6x6mm) 1/4" x 1/4"	Hoppers, Magnet, Bases	Nema- 12
		Collectors, Take-Out Tube	Strobe Light
		Color	Horn
		Gear Ratio, <b>Cleanroom</b>	Proximity Switch
		Pellet Mover Systems	
		Fine Separator Systems	
		Blower Evacuation System	

\*Throughput and capacity will vary depending on material type, diameter and size of runner. It is also dependent on cutter size and gear ratio provided.

^ Based on standard unit, custom features or options may change information provided.